

LED 400W MOVING HEAD (BSW400)

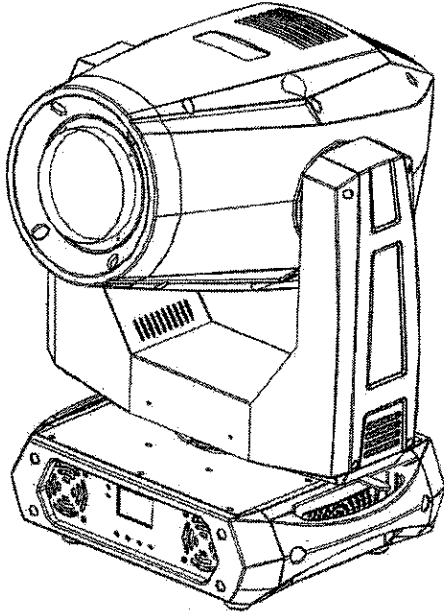

User Manual

Please read this user manual before using this product.



INDEX

STATEMENT	3
ACCESSORIES	3
SAFETY INSTRUCTION	3
GENERAL GUIDELINES	4
INSTALLATION	6
TECHNICAL SPECIFICATION	8
GOBO AND LAMP	11
CONTROL SYSTEM	12
CONTROL PANEL	13
HOW TO SET THE UNIT	14
CHANNEL DESCRIPTION:	21
TROUBELSHOOTING	24
CLEANING AND MAINTENANCE	26

STATEMENT

The product has well capability and intact packing when leave factory. All of the user should comply with warning item and manual, any misuse cause of the damages are not included in our guarantee, and also cannot be responsible for any malfunction & problem owing to ignore the manual.

ACCESSORIES

These items are packed together with the product:

Name	Quantity	Unit	Remark
USER MANUAL	1	PCS	
DMX CABLE	1	PCS	
OMEGA	2	PCS	
CLAMP	2	PCS	
SATETY ROPE	1	PCS	

SAFETY INSTRUCTION

Please keep this User Guide for future consultation. If you sell the unit to another user, be sure that they also receive this instruction booklet.



This fixture is an extremely sophisticated piece of electronic equipment. To guarantee a smooth operation, it is important to follow the guidelines in this manual. The manufacturer of this device will not accept responsibility for damages resulting from the misuse of this fixture due to the disregard of the information printed in this manual.



This device falls under **PROTECTION CLASS 1**. It's essential this device be grounded properly. Only qualified personnel should perform all electrical connections.



I N D O O R S U S E O N L Y I
DO NOT EXPOSE FIXTURE RAIN AND MOISTURE!



UNPLUG POWER BEFORE SERVICING FIXTURE!
DO NOT PLUG FIXTURE INTO A DIMMER PACK!
NEVER TOUCH FIXTURE DURING OPERATION, AS IT MAY BE HOT!



NEVER LOOK DIRECTLY INTO THE LIGHT SOURCE!
SENSITIVE PERSONS MAY SUFFER AN EPILEPTIC SHOCK!

GENERAL GUIDELINES

- ◆ **NEVER OPEN THIS FIXTURE WHILE IN USE!**
- ◆ During the initial operation of this fixture, a light smoke or smell may emit from the interior of the fixture. This is a normal process and is caused by excess paint in the interior of the casing burning off from the heat associated with the lamp and will decrease gradually over time.
- ◆ This fixture is a professional lighting effect designed for **INDOOR / DRY LOCATIONS ONLY** on stage, in nightclubs, theatres, etc.

- ◆ Please make sure there are **NO FLAMMABLE MATERIALS** close to the fixture while operating, to prevent any fire hazard.
- ◆ The fixture must be installed in a location with adequate ventilation, at least 1.5 feet (.5m) from adjacent surfaces. Be sure no air ventilation slots are blocked.
- ◆ **DO NOT** attempt installation and/or operation without knowledge how to do so.
- ◆ **DO NOT** permit operation by persons who are not qualified to operate this type of fixture. Most damages are the result of operations by nonprofessionals. Consistent operational breaks may ensure the fixture will function properly for many years to come.
- ◆ **DO NOT** shake fixture, avoid brute force when installing and/or operating fixture.
- ◆ Always install the fixture with an appropriate safety cable. When installing the fixture in a suspended environment, always use mounting hardware that is no less than M10 x 25 mm, also be sure the hardware is insert in the pre-arranged screw holes in the bracket of the fixture.
- ◆ Use the original packaging and materials to transport the fixture in for service.
- ◆ **DO NOT TOUCH** the housing bare-hand during its operation. Turn OFF the power and allow approximately 15 minutes for the fixture to cool down before replacing or serving.

INSTALLATION



FLAMMABLE MATERIAL WARNING

Keep fixture at least 5.0 ft (1.5m) away from any flammable materials, decorations, pyrotechnics, etc.



ELECTRICAL CONNECTIONS

A qualified electrician should be used for all electrical connections and/or installations.

CAUTIONS

- ◆ For added protection, mount the fixture in areas outside walking paths, seating areas, or in areas where unauthorized personnel might reach the fixture.
- ◆ Ambient operating temperature range for this fixture is **5° to 113°F. (-15° to 45°C)** Do not use the fixture under or above this temperature.
- ◆ Before mounting the fixture to any surface, make sure the installation area can hold a minimum point load of 10 times the weight of the fixture.
- ◆ Fixture installation must always be secured with a secondary safety attachment, such as an appropriate safety cable.
- ◆ Never stand directly below the device when mounting, removing or servicing.

The unit should be mounted via its screw holes on the bracket. Always ensure that the unit is firmly fixed to avoid vibration and slipping while operating. And make sure that the structure to which you are attaching the unit is secure and is able to support a weight of 10 times of the unit's weight. Also always use a

safety cable that can hold 12 times of the weight of the unit when installing the fixture.

The equipment must be fixed by professionals. And it must be fixed at a place where is out of the touch of people.

Clamp mounting

The moving head provides a unique mounting bracket assembly that integrates the bottom of the base, the included '**Omega Bracket**' and the **Safety Cable** rigging point in one unit (see the illustration below). When mounting this fixture to truss be sure to secure an appropriately rated clamp to the included **Omega Bracket** using a M10 screw fitted through the center hole of the 'omega bracket'. As an added safety measure be sure to attached at least one properly rated **Safety Cable** to the fixture using one of the safety cable rigging point integrated in the base assembly.

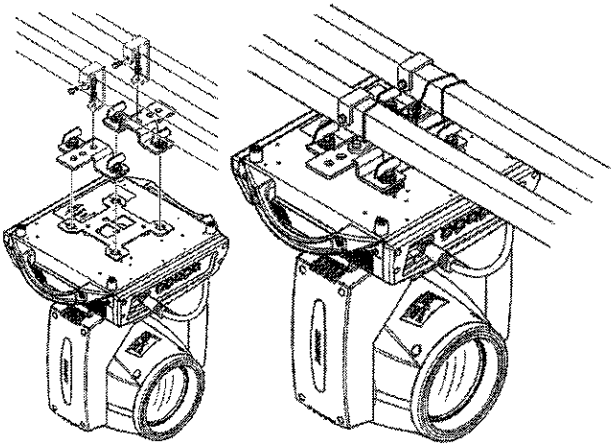

DMX-512 control connection:

Connect the provided XLR cable to the female 3-pin XLR output of your controller and the other side to the male 3-pin XLR input of the moving head. You can chain multiple Moving head together through serial linking. The cable needed should be two core, screened cable

with XLR input and output connectors. Please refer to the diagram below.

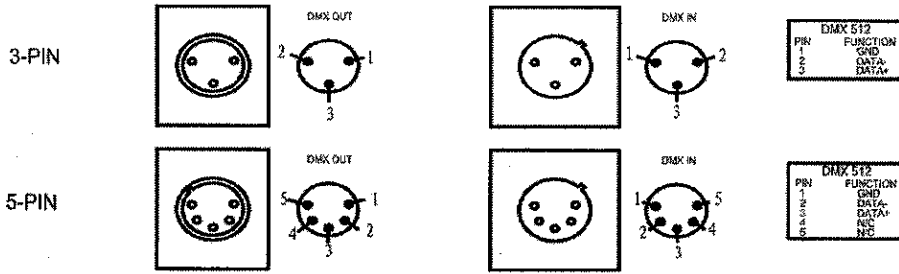

DMX-512 connection with DMX terminator:

For installations where the DMX cable has to run a long distance or is in an electrically noisy environment, such as in a discotheque, it is recommended to use a DMX terminator. This helps in preventing corruption of the digital control signal by electrical noise. The DMX terminator is simply an XLR plug with a 120 resistor connected between pins 2 and 3, which is then plugged into the output XLR socket of the last fixture in the chain. Please see illustrations below.

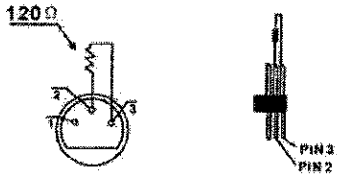

TECHNICAL SPECIFICATION

Power supply

- AC 100~240V 50/60Hz

Power Consumption - 430W

Fuse- T 6.3A

Light Source

- 400W White LED

Optical system

- High efficiency optical system, delivering extremely powerful output
- High quality dichroic lenses

Movement

- Pan: 540°
- Tilt: 270°
- Pan/Tilt moving speed adjustable.
- Automatic Pan/Tilt correction.
- Easy calibration and maintenance by magnetic home positioning.
- Pan/Tilt position lock for transporting protection.

Dimmer/Shutter

- Blackout, 0~100% smooth dimming, independent shutter and various strobe effect.

Color wheel

- Color wheel: 10 fixed colors plus white
- Rainbow effect in both directions.

Gobo wheel

- Gobo Wheel : 1 Static gobo wheel with 11 gobos plus open
- 1 Rotating gobo wheel with 7 gobos plus open
- Easy calibration and maintenance by magnetic home positioning.
- Module design for easy assembly and service.

Prism

- Prism: 3 facet prism rotating in both directions

Frost

- Variable, separate effect.

Focus

- Independent frost effect

Zoom

- Motorized linear zoom for smooth adjustment of beam size and beam sharpness.

Cool

- Fan cooled

Protocols

- DMX 512
- Data input/output: 3/5 Pin XLR socket

Weight

- 21Kg

Dimension

- 408× 293×655mm

Photometric Diagram:

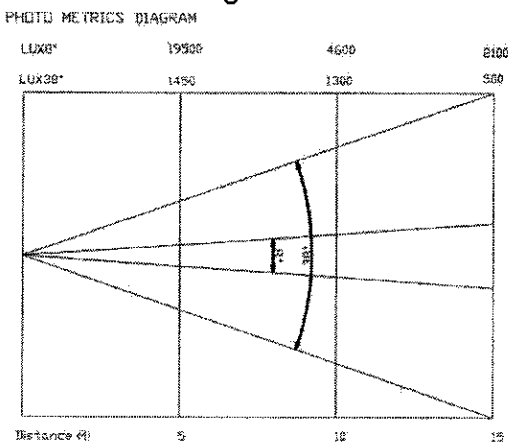

Please Note: Specifications and improvements in the design of this unit and this manual are subject to change without any prior written notice.

GOBO AND LAMP

1. Gobos

GOBO:

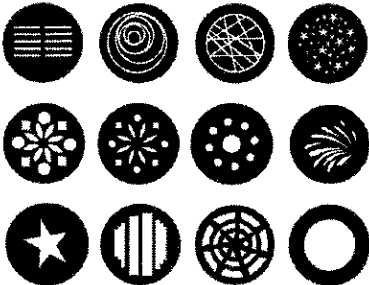

ROTATING GOBO:

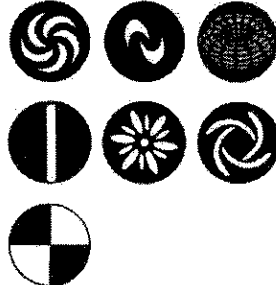

DANGER!

*Install the gobos with the device switched off only.
Unplug from mains before changing gobos!*

CAUTION: Never unscrew the screws of the rotating gobo as the ball bearing will otherwise be opened!

2. 300W White LED

Because of its high internal pressure, there might be a risk that the Discharge lamp would explode during operation. The lamp emits intense UV radiation which is harmful to the eyes and skin. The high luminance of the arc can cause severe damage to the retina if you take a close look at the lamp.

- To protect the lamp, always turn off the lamp first (via control panel or DMX controller) and let the unit run at least five minutes to cool down before

switching off the mains supply. Never handle the lamp or luminary when it is hot.

- Do not touch the bulb with bare hands. If this happens, clean the lamp with denatured alcohol and wipe it with a lint free cloth before installation.
- The lamp generates UV radiation. Never operate the lamp without appropriate shielding.
- When lighting up, the lamp operates at high pressure and there is a slight risk of arc tube rupture. The risk increases with age, temperature and improper handling of the lamp. Do not use the lamp longer than its lifespan.
- Make sure the lamp is located in the center of the reflector for the best projection.

CONTROL SYSTEM

The DMX512 is widely used in intelligent lighting control, with a DMX 512 controller. Connect several lights together dmx in and dmx out,

3 pin XLR connectors: Pin 1: GND, Pin 2: Negative signal (-), Pin 3: Positive signal (+)

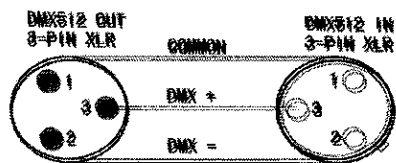
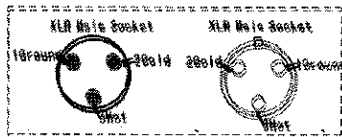
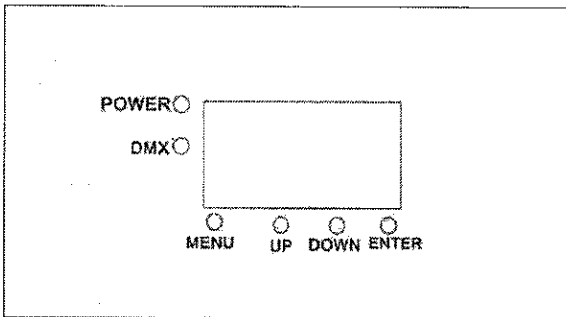

Figure 2



XLR Pin Configuration
pin 1: GND
pin 2: DMX (-) (negative)
pin 3: DMX (+) (positive)

CONTROL PANEL



1. Monitor (Batter Back-up display):

2. LED:

POWER	ON	Power on
DMX	ON	DMX input present

3. Button:

MENU	To enter into move backward or leave the menu
▲ UP	To go backward to move up in the menu
▼ DOWN	To go to move down in the menu
ENTER	To perform the desired functions

4. DMX input/output:

For DMX 512 operation, use 3/5-pin XLR plug cable to link the units together.

5. Power Cable:

To connect to the mains supply

6. Fuse (T 6.3A):

Protect the unit from damage of over current.

7. Power Switch: Turns On/Off the power.

HOW TO SET THE UNIT

Main Function

Turn on the unit, press the MENU button into menu mode, and press the UP/DOWN button until the required function is shown on the monitor. Select the function by the ENTER button. Use the UP/DOWN button to choose the submenu, press the ENTER button to store and automatically return to the last menu. Press the MENU button or let the unit idle one minute to exit menu mode.

In the event of disconnecting with mains power, press the UP button for one minute to enter into menu mode. Press MENU button or let the unit idle one minute to exit.

First level	Secondary level	Third level	Fourth level
DMX address	DMX address=xxx		
Reset	Are You Sure		
Display Options	DMX Mode	Display on Always	
		Display off After Delay	
	Display Invert	Display Invert off	
		Display Invert on	
	Display Dimming	Disp Dim Level Min	
		Disp Dim Level Min 1	
		Disp Dim Level Min 2	
		Disp Dim Level Min 3	
		Disp Dim Level Min 4	
		Disp Dim Level Min 5	
		Disp Dim Level Min 6	
Disp Dim Level Min 7			

		Disp Dim Level Min 8	
		Disp Dim Level Min 9	
	Display Contrast	Display Contrast xx(1-21)	
System options	Loss of DMX	When DMX is Lost Normal time out	
		When DMX is Lost Hold Last Value	
	Factory Settings	Press button DOWN/ UP/ENTER at the Same time to enter This menu)	Pass Code
Option Settings	Pan DMX Invert	Pan DMX Invert off	
		Pan DMX Invert on	
	Tilt Invert	Tilt DMX Invert off	
		Tilt DMX Invert on	
	Pan Tilt Swap	Pan Tilt Swap off	
		Pan Tilt Swap on	
	Dimmer Invert	Dimmer Invert OFF	
		Dimmer Invert ON	
	Zoom Invert	Zoom Invert OFF	
		Zoom Invert ON	
	Defaults	OFF Restore Defaults	
	Information	Lamp Hours	Lamp Hours =xx
Reset Lamp Hours Are You Sure(UP/DOWN)			

	Total Hours	Total Hours =xx	
Temperature		Display Board	Display Board System=xx°C Boot=xx°C
		Driver Board 1	Display Board 1 System=xx°C Boot=xx°C
		Driver Board 2	Display Board 2 System=xx°C Boot=xx°C
		Driver Board 3	Display Board 3 System=xx°C Boot=xx°C
		Pan and Tilt	Pan and Tilt System=xx°C Boot=xx°C
		LED Driver	Led=°C
	View DMX Values	DMX Channel 1=xxx	
Electronic SN	Electronic SN= *****		
RDM Device label	RDM Device Label ANSI E1.20 RDM Version X.X		
Pan Encoder	Wiring Normal Pan Err 0 Count 50880		
Tilt Encoder	Wiring Normal Tilt Err 0 Count 28080		

		Driver Faults	X Over Temp 0 Y Over Temp 0 X Fault 0 Y Fault 0		
Test Modes	Factory Setup		Factory Setup OFF		
			Factory Setup ON		
	Self Test		Self Test OFF		
			Self Test ON		
Stand Alone	Operation Mode= DMX Operation		User Memory 1		
			User Memory 2		
	Operation Mode= Master Mode		User Memory 1		
			User Memory 2		
	Operation Mode= Slave Mode				
	Operation Mode Static Scene				
First level	Secondary level	Third level	Fourth level	Five level	Six level
User Memories	Edit User Memory	User memory 1	Scene xx (1-200scenes)	Shutter Dimmer Dimmer low Color Wheel Fixed Gobo	Shutter Xxx Dimmer Xxx Dimmer Low xxx Color Wheel xxx Fixed Gobo

					xxx
				R Gobo Wheel	R Gobo Wheel XXX
				R Gobo Rotate	R Gobo Rotate XXX
				R Prism Rotate	R Prism Rotation XXX
				R Prism2 In Out	R Prism 2 In out XXX
				Zoom	ZOOM XXX
				Focus	Focus XXX
				Frost	Frost XXX
				Diffuser	Diffuser XXX
				Pan Coarse	Pan xxx
				Pan Fine	Pan Fine xxx
				Tilt Coarse	Tilt xxx
				Tilt Fine	Tilt Fine xx
				M Speed	M-Speed XXX
				Delay	(0.25s-100min)
				Link To Step	XXX(1-200)
		User memory2	Scene XX (1-200Scenes)	Shutter	Shutter XXX
				Dimmer	Dimmer XXX
				Slow Dimmer	Slow Dimmer xxx
				Color Wheel	Color Wheel xxx
				Fixed Gobo	Fixed Gobo xxx

				R Gobo Wheel	R Gobo Wheel XXX
				R Gobo Rotate	R Gobo Rotate XXX
				R Prism Rotate	R Prism Rotation XXX
				R Prism2 In Out	R Prism 2 In out XXX
				Zoom	ZOOM XXX
User Memories	Edit User Memory	User memory2	Scene XX (1-200Scenes)	Focus	Focus XXX
				Frost	Frost XXX
				Diffuser	Diffuser XXX
				Pan Coarse	Pan xxx
				Pan Fine	Pan Fine xxx
				Tilt Coarse	Tilt xxx
				Tilt Fine	Tilt Fine xx
				M Speed	M-Speed XXX
				Delay	Delay xx s (0.25s-100min)
				Link To Step	XXX(1-200)
		Static Scene	Shutter	Shutter XXX	
			Dimmer	Dimmer XXX	
			Dimmer LOW	Dimmer Low xxx	
			Color Wheel	Color Wheel XXX	

			Fixed Gobo	Fixed Gobo XXX	
			R Gobo Wheel	R Gobo wheel XXX	
			R Gobo Rotate	R Gobo Rotate XXX	
			R Prism Rotate	R Prism Rotation XXX	
			R Prism2 In Out	R Prism 2 In out XXX	
			Zoom	ZOOM XXX	
			Focus	Focus XXX	
			Frost	Frost XXX	
			Diffuser	Diffuser XXX	
			Pan	Pan xxx	
			Pan Fine	Pan Fine xxx	
			Tilt	Tilt Xxx	
			Tilt Fine	Tilt Fine Xxx	
			M-Speed	M-Speed xxx(000-255)	

Init User memory	Reset User memory1	Reset User1 Unlock2,3,4(Press buttons2,3,4,iebuttonsUP/DOWN/ENTER to execute the function)	1 User memory 1 has been reset
	Reset User memory2	Reset User2 Unlock2,3,4(Press buttons2,3,4,iebuttonsUP/DOWN/ENTER to execute the function)	User memory 2 has been reset
	Reset Static Scene	Reset Static Scene2,3,4(Press buttons2,3,4,iebuttonsUP/DOWN/ENTER to execute the function)	Static Scene has been reset

CHANNEL DESCRIPTION:

24H	VALUE	FUNCTION
CH1 Strobe	000-003	Open
	004-103	Strobe Slow -Fast
	104-107	Open
	108-207	Slow Open, Slow Close
	208-212	Open
	213-251	Macros strobe
	252-255	Open
CH2 Dimmer	000-255	Linear Dimming(0-100%)
CH3 Pan	000-255	Pan (0-540)
CH4 Pan Fine	000-255	Pan Fine
CH5 Tilt	000-255	Tilt (0-270)
CH6 Tilt Fine	000-255	Tilt Fine
CH7 Pan/Tilt Speed	000-255	Fastest -Slowest
CH8 Cyan	000-255	Linear adjustment from light to dark for Cyan
CH9 Magenta	000-255	Linear adjustment from light to dark for Magenta

CH10 Yellow	000-255	Linear adjustment from light to dark for Yellow
CH11 CTO	000-255	Linear adjustment from light to dark for CTO
CH12 CMY Macros	000-255	Macros
CH13 Color	000-255	Color
CH14 IRIS	000-255	Big to small
CH15 Fix Gobo	000-010	Open
	011-020	GOBO 1
	021-030	GOBO 2
	031-040	GOBO 3
	041-050	GOBO 4
	051-060	GOBO 5
	061-070	GOBO 6
	071-080	GOBO 7
	081-090	GOBO 8
	091-100	GOBO 9
	101-110	GOBO 10
	111-128	GOBO 11
	129-164	Rotate Forward Fast to Slow
	165-200	Rotate Forward Slow to Fast
	201-205	GOBO1 Shake
	206-210	GOBO2 Shake
	211-215	GOBO3 Shake
	216-220	GOBO4 Shake
	221-225	GOBO5 Shake
	226-230	GOBO6 Shake
231-235	GOBO7 Shake	
236-240	GOBO8 Shake	
241-245	GOBO9 Shake	
246-250	GOBO10 Shake	

	251-255	GOBO11 Shake
CH 16R Gobo Wheel	00-008	Open
	009-016	Slot 1
	017-024	Slot 2
	025-032	Slot 3
	033-040	Slot 4
	041-048	Slot 5
	049-056	Slot 6
	057-064	Slot 7
	065-072	Slot 1 Shake
	073-080	Slot 2 Shake
	081-088	Slot 3 Shake
	089-096	Slot 4 Shake
	097-104	Slot 5 Shake
	105-112	Slot 6 Shake
	113-127	Slot 7 Shake
	128-189	Rotate Forward Fast to Slow
	190-193	Stop
194-255	Rotate Forward Slow to Fast	
CH 17 R GOBO Rotate	000-127	Will do some static position for now
	128-189	Rotate Forward Fast to Slow
	190-193	Stop
	194-255	Rotate Forward Slow to Fast
CH 18	000-255	Nothing
CH 19 Prism	000-007	OUT
	008-255	IN
CH 20 Prism Rotate	000-128	Will do some static position for now
	129-190	Rotate Forward Fast to Slow
	191-193	Stop

	194-255	Rotate Forward Slow to Fast
CH 21 Zoom	000-255	0%--100%
CH 22 Focus	000-255	0%--100%
CH 23 Frost	000-255	Frost
CH 24 Control	000-039	Nothing
	040-069	Reset All
	070-079	Nothing
	080-089	Set Blackout while Pan/Tilt moving
	090-099	Cancel Black out while Pan/Tilt moving
	100-109	Set Blackout while Gobo changing
	110-119	Cancel Black out while Gobo changing
	120-255	Nothing

TROUBLESHOOTING

Following are a few common problems that may occur during operation. Here are some suggestions for easy troubleshooting:

A. The unit does not work, no light and the fan does not work

1. Check the connect power and main fuse.
2. Measure the mains voltage on the main connector.
3. Check the power on LED to see if it can be light up or not.

B. Not responding to DMX controller

1. DMX LED should be on. If not, check DMX connectors, cables to see if they are linked properly.
2. If the DMX LED is on and no response to the channel, check the address settings and DMX polarity.
3. If you have intermittent DMX signal problems, check the pins on connectors or on PCB of the unit or the previous one.

4. Try to use another DMX controller.
 5. Check to see if the DMX cables run near or run alongside to high voltage cables that may cause damage or interference to DMX interface circuit.
- C. One of the channels is not working well
1. The stepper motor might be damaged or the cable connected to the PCB is broken.
 2. The motor's drive IC on the PCB might be out of condition.
- D. The lamp is cutting out intermittently
1. The lamp is not working well. Check the mains voltage either too high or too low.
 2. Internal temperature may be too high. Check if replacement of fan is needed on the head.
- E. If The pan belt is broken
1. Turn off the mains power.
 2. Loosen the screws (A), open the cover.
 3. Loosen the screws (B).
 4. Unplug all the connect wires over the belt.
 5. Change a new belt (C), put the belt around the axis gear and motor gear.
 6. Plug all the connect wires back upon the belt.
 7. Tighten all the screws.
- F. If The tilt belt is broken
1. Turn off the mains power.
 2. Loosen all the screws (A) and open the right arm cover (B).
 3. Loosen the screws (C) that fix the bridge.
 4. Change a new belt (D). Please adjust the tension of the belt properly.
Note: do not fix the belt too tight as it is can easily rupture.
 5. Reverse the procedures from step 3 to 2.

CLEANING AND MAINTENANCE

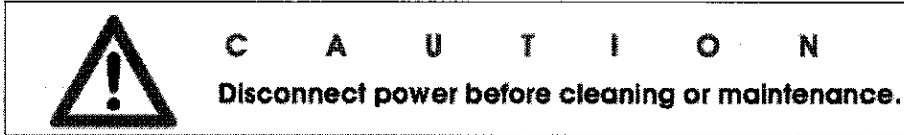

Following are a few common problems that may occur during operation. Here are some suggestions for easy troubleshooting:

CLEANING

Frequent cleaning is recommended to insure proper function, optimized light output, and an extended life. The frequency of cleaning depends on the environment in which the fixture operates: damp, smoky or particularly dirty environments can cause greater accumulation of dirt on the fixture's optics.

- Clean the external lens surface at least every 20 days with a soft cloth to avoid dirt/debris accumulation.
- Never use alcohol, solvents, or ammonia based cleaners.

MAINTENANCE

Regular inspections are recommended to insure proper function and extended life. There are no user serviceable parts inside this fixture, please refer all other service issues to an authorized service technician. Should you need any spare parts, please order genuine parts from your local dealer.

Please refer to the following points during routine inspections:

- A detailed electric check by an approved electrical engineer every three months, to make sure the circuit contacts are in good condition and prevent overheating.
- Be sure all screws and fasteners are securely tightened at all times. Loose screws may fall out during normal operation resulting in damage or injury as larger parts could fall.
- Check for any deformations on the housing, color lenses, rigging hardware and rigging points (ceiling, suspension, trussing). Deformations in the housing could allow for dust to enter into the fixture. Damaged rigging points or unsecured rigging could cause the fixture to fall and seriously injure a person(s).
- Electric power supply cables must not show any damage, material fatigue or sediments. Never remove the ground prong from the power cable.